

Contents list available at [Sinta](https://sinta)**A R M A T U R**

: Artikel Teknik Mesin & Manufaktur

Journal homepage: <https://scholar.ummetro.ac.id/index.php/armatur>**Analysis Of Efficiency Ratio And Coefficient Of Performance (COP) In AC Split Using R-22 Refrigerant****Rifaldo Pido^{1*}, Rahmad Hidayat Boli², Yusuf Hamdani³**^{1,2,3}Mechanical Engineering Study Program, University of Gorontalo
Jalan.A.A Wahab Kec. Limboto Kab. Gorontalo, Gorontalo 96150, Indonesia**A R T I C L E
I N F O**

Keywords:
Efisiensi thermal
COP
AC Split
Refrigeran
R22

A B S T R A C T

Cooling machine technology functions to keep the temperature cool, so this technology is very important for our daily lives, this study aims to analyze the thermal efficiency and Coefficient of Performance in a split AC system using R-22 refrigerant. This study uses an experimental method where system operational data, such as temperature, pressure, and electricity consumption are measured directly at various load conditions. The main parameters analyzed include system thermal efficiency and COP, which show the energy performance of the cooling system. The results of this study indicate that thermal efficiency and COP are influenced by variations in ambient temperature and cooling load. At higher ambient temperatures, system performance tends to decrease, indicated by a decrease in COP and thermal efficiency. These findings provide important insights into the performance of split AC with R22 refrigerant under various operating conditions, which can be used to develop strategies to improve energy efficiency in air conditioning systems.

Introduction

Refrigeration technology functions to keep the temperature cool, so this technology is very important for our daily lives [1]. One of the points of energy use that is quite large in Indonesia is the use of electrical energy to drive the air conditioning system [2]. A refrigerator is a tool used to release heat from an object or

object and also from a room to the surrounding environment so that the object or room The temperature change is lower than the scope of its environment [3]. The cooling or refrigeration process is essentially a process of transferring heat energy contained in the room. According to the law of conservation of energy, we cannot remove energy but can only transfer it from substances and other substances. For the purpose

*Corresponding author: rifaldopido813@gmail.com

DOI: <https://10.24127/armatur.v6i1.8167>

Received January 28, 2025; Received in revised form March 16, 2025; Accepted March 18, 2025

Available online March 19, 2025

of transferring heat energy in space, a heat exchange fluid is needed, called a refrigerant [4].

Refrigerant R22 has long been used as a working fluid in refrigeration machines (freezers) and air conditioners (AC). [5], [6] As a working fluid, thermodynamically, R22 can produce optimal performance in refrigeration machines [7]. Various efforts have been made to find environmentally friendly alternative refrigerants [8]. Based on this background, the problem in this study can be formulated as follows: how is the thermal efficiency and COP value of a Split AC refrigeration machine using refrigerant R-22 [9], [10].

Methodology

The research method used is carried out using observation and experimental methods, starting with field studies.

The methods used in this writing are as follows:

1. Literature study This method is used to obtain the basis for writing and references in compiling research
2. Conducting research/testing recording on each stage of research results where in the use of Refrigerant R22, then carried out when the AC is on and stable. Testing is carried out using an AC trainer that we made, data collection in this study was carried out when the AC was on and stable. Testing is carried out using an AC trainer that we made, data collection in this study was carried out in the Energy Conversion laboratory.

Some data from the test include:

- a. In/in and Out/out temperatures on the Evaporator.
- b. In/in and Out/out temperatures on the Condenser.
- c. In/in and Out/out air temperatures on the Evaporator.
- d. Suction and Discharge Pressure
- e. Voltage
- f. Current Strength
- g. Evaporator Exit Air Velocity.



Figure 1. Test equipment installation

Temperature data collection is done using a digital thermometer, and to collect pressure data using a pressure gauge. gauge, and use an anemometer to measure the air velocity coming out of the evaporator fan.

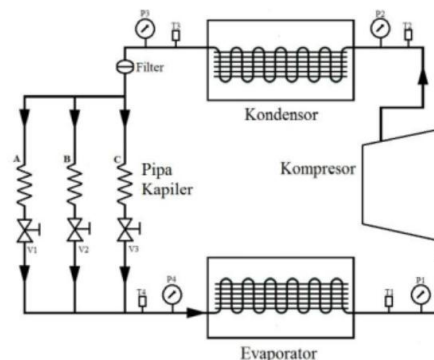

Figure 2. Schematic of experimental equipment circuit. 1. Pressure gauge (P), 2. Thermometer (T), 3. Capillary tube (V) [11].

Table 1. Tools and materials

Name	Specification
AC split	1 PK
Pressure gauge	Wie broek (analog)
Thermometer	Model digital
Ampere meter	Model digital
Refrigerant	R22
Volt meter	Model digital
Caliper Pipe	NS

Split AC performance is measured using the Carnot cycle Coefficient of Performance (COP) as the basis for calculations with the equation [11].

$$COP_{carnot} = \frac{T_{evaporasi}}{T_{kondensasi} - T_{evaporasi}} \quad (1)$$

Actual COP is the actual COP owned by a system using equations.

$$COP_{actual} = \frac{ER}{W_k} = \frac{h_1 - h_4}{h_2 - h_1} \quad (2)$$

And also to determine the Energy Efficiency Ratio (EER) value you can use the equation.

$$EER = COP \times 3,41 \quad (3)$$

Energy Efficiency Ratio (EER) is the comparison of cooling capacity with power input, the higher the EER value, the more efficient the AC is. The heat absorbed by the evaporator or the cooling effect q_e is calculated as the difference in refrigerant entrapment leaving and entering the evaporator using the equation [11].

$$q_e = h_1 - h_4 \quad (4)$$

Where:

h_1 = Refrigerant Enthalpy leaving the evaporator (kJ/kg)

h_4 = Refrigerant Enthalpy entering the evaporator (kJ/kg)

Compressor work W is calculated based on the increase in Refrigerant enthalpy due to power input from the compressor. W is calculated using the equation [11].

$$W = h_2 - h_1 \quad (5)$$

Dimana :

h_1 = Enthalpi Refrigerant masuk ke kompresor (kJ/kg)

h_2 = Enthalpi Refrigerant keluar dari kompresor (kJ/kg)

After knowing the value of the Carnot COP and the actual COP, the efficiency of the split AC can be determined using the equation:

$$\eta = \frac{COP_{actual}}{COP_{carnot}} \times 100 \% \quad (6)$$

Results And Discussion

From the p-h diagram of refrigerant R-22, it is obtained

$$\begin{aligned} h_1 &= 23,87 \text{ kJ/kg} \\ h_2 &= 759,64 \text{ kJ/kg} \\ h_3=h_4 &= 576,93 \text{ kJ/kg} \end{aligned}$$

So that the compression work value (W_k) is obtained

$$\begin{aligned} W_k &= h_2 - h_1 \\ &= 759,64 \text{ kJ/kg} - 23,87 \text{ kJ/kg} \\ &= 535,77 \text{ kJ/kg} \end{aligned}$$

To calculate the heat dissipation in the condenser, use the equation:

$$\begin{aligned} q_c &= h_2 - h_3 \\ &= 759,64 \text{ kJ/kg} - 576,93 \text{ kJ/kg} \\ &= 182,71 \text{ kJ/kg} \end{aligned}$$

Next, calculate the refrigeration effect value using the equation:

$$\begin{aligned} ER &= h_1 - h_4 \\ &= 23,87 \text{ kJ/kg} - 576,93 \text{ kJ/kg} \\ &= -553,06 \text{ kJ/kg} \end{aligned}$$

As for calculating the Carnot COP value, it is obtained

$$\begin{aligned} COP_{carnot} &= \frac{T_{evaporasi}}{T_{kondensasi} - T_{evaporasi}} \\ &= \frac{295,76 \text{ }^\circ\text{K}}{332,87 \text{ }^\circ\text{K} - 295,76 \text{ }^\circ\text{K}} \\ &= 7,96 \text{ }^\circ\text{K} \end{aligned}$$

So that the COP carnot on the split AC using the R-22 refrigerant is 7.96 °K. As for calculating the actual COP, it is obtained by using the equation:

$$\begin{aligned} COP_{Actual} &= (ER) / (W_k) \\ &= \frac{146,94 \text{ kJ/kg}}{35,77 \text{ kJ/kg}} \\ &= 4,10 \end{aligned}$$

After knowing the value of the Carnot COP and the actual COP, the efficiency of the split AC can be determined using the equation:

$$\begin{aligned}\eta &= \frac{COP_{actual}}{COP_{carnot}} \times 100 \% \\ &= \frac{4,10}{7,96} \times 100 \% \\ &= 51,50 \%\end{aligned}$$

To get the EER value, you can use the equation:

$$\begin{aligned}EER &= COP_{Actual} \times 3,41 \\ &= 4,10 \times 3,41 \\ &= 13,98 \text{ Btu/h}\end{aligned}$$

The calculation results indicate that the cooling system using R-22 refrigerant has an actual COP of 4.10 with an efficiency of 51.50% compared to the Carnot COP. This suggests that there is still room for improving the system's efficiency. Several factors can influence the efficiency of this system, including:

Refrigerant Quality:

R-22 refrigerant has thermodynamic characteristics that affect the performance of the cooling system. Currently, many systems have switched to more environmentally friendly refrigerants such as R-410A or R-32 due to regulatory requirements and better efficiency.

Operational Conditions:

1. The evaporator and condenser temperatures significantly determine the COP. If the condensation temperature is high due to poor ventilation or suboptimal condenser performance, the system's efficiency will decrease.
2. A lower evaporation temperature can also increase compressor power consumption.

Compressor Efficiency:

1. The design and performance of the compressor greatly affect energy consumption. A high-efficiency compressor can reduce energy usage.
2. The use of inverter technology in AC systems can improve efficiency by adjusting the compressor speed according to demand.

Condenser and Evaporator Performance:

1. A clean condenser with good airflow can enhance heat dissipation, thereby improving COP.
2. A dirty or obstructed evaporator can reduce heat exchange effectiveness, ultimately lowering cooling capacity.

Environmental Factors:

1. Ambient temperature also plays a crucial role in the efficiency of the cooling system. If the surrounding environment is hot, the condenser will struggle to release heat efficiently, increasing compressor workload.
2. High air humidity can add to the cooling load due to condensation on the evaporator.

System Design and Installation:

1. The length and diameter of the refrigerant pipes affect pressure and energy losses within the system. A suboptimal design can lead to a decrease in COP.
2. Proper thermal insulation of refrigerant pipes also helps reduce energy losses.

Implications and Improvement Suggestions:

To enhance the efficiency of this cooling system, several steps can be taken:

1. **Optimizing Condensation and Evaporation Temperatures:** Ensuring an optimal temperature difference between the condenser and evaporator so that the system operates at maximum efficiency.
2. **Using Alternative Refrigerants:** Replacing R-22 with more environmentally friendly and efficient refrigerants such as R-410A.
3. **Regular Maintenance:** Cleaning air filters, evaporators, and condensers regularly to maintain system performance.
4. **Utilizing Inverter Technology:** This technology can improve efficiency by adjusting compressor power according to cooling needs.

5. **Improving Insulation Systems:**
Keeping refrigerant pipes well-insulated to prevent energy losses.

Overall, this analysis provides insights into the performance of the cooling system using R-22 and the opportunities for efficiency improvement. By implementing improvements in both technical and operational aspects, the cooling system can operate more optimally with lower energy consumption.

CONCLUSION

Based on the research conducted on the Split AC system using R-22 refrigerant, several important results were obtained regarding system performance. The actual coefficient of performance (COP) obtained from calculations is 4.10, indicating that the AC system has good thermal efficiency, where the energy used to operate the system effectively produces significant cooling according to the cooling load. Additionally, the efficiency ratio obtained in this study is 13.98 Btu/h, representing the system's ability to produce cooling per unit of electrical energy used. These results demonstrate that the performance of the Split AC system with R-22 refrigerant falls within an efficient range for the specified operating conditions.

ACKNOWLEDGEMENTS

The author would like to express his deepest gratitude to all parties who have provided support and contributions in the implementation of this research. Thanks to colleagues in the laboratory team who helped in data collection and analysis.

References

- [1] M. M. Dwinanto, "Simulasi Kinerja AC Split Menggunakan R32, R410A, R290, dan R1234YF," *LONTAR J. Tek. Mesin Undana*, vol. 10, no. 01, pp. 62–68, 2023, doi: 10.35508/ljtmu.v10i01.14245.
- [2] A. Ramli Rasyid, "Analisis Unjuk Kerja (COP) Mesin Pendingin Hibrid dengan Menggunakan Refrigeran R-22," *J. Teknol.*, vol. 17, no. 1, pp. 49–58, 2017.
- [3] Y. Hariyanto, D. N. Zulfika, and L. Hakim, "Analisa Performansi Dan Ekonomis Mesin Pendingin Air Conditioner 1 Pk Menggunakan Refrigerant R22a Dan R290a," *Semin. Nas. Fak. Tek.*, vol. 1, no. 1, pp. 337–341, 2022, doi: 10.36815/semastek.v1i1.56.
- [4] N. Azmi, J. T. Kimia, P. N. Malang, J. Soekarno, and H. No, "Efektivitas Perpindahan Panas Pada Alat Double Pipe Heat Exchanger," vol. 9, no. 9, pp. 77–85, 2023.
- [5] F. Fachruddin, M. Maimun, and M. S. Aliredjo, "Chilling System Insulation Hatch Design Using Refrigeration For 3GT Sized Vessels," *Int. J. Adv. Eng. Res. Sci.*, vol. 8, no. 2, pp. 127–132, 2021, doi: 10.22161/ijaers.82.16.
- [6] D. Kong, N. Wei, and M. Dong, "Research on nano refrigerant and nano lubricant to improve energy saving of refrigeration system," *J. Phys. Conf. Ser.*, vol. 2093, no. 1, pp. 0–5, 2021, doi: 10.1088/1742-6596/2093/1/012016.
- [7] T. P. Pramudantoro, "Pengaruh Variasi Massa Pengisian R290 Sebagai Refrigeran Pengganti R22 Pada Kinerja Freezer," *ReTII*, pp. 0–5, 2017, [Online]. Available: <https://journal.itny.ac.id/index.php/ReTII/article/view/652>
- [8] I. W. Temaja, M. Ery Arsana, and L. P. Ike Midiani, "Kajian Eksperimental Campuran R-32/R-290 Pengganti Refrigeran R-32 Pada Ac Split Domestik," *Matrix*, vol. 8, no. 3, pp. 74–78, 2018, [Online]. Available: <http://download.garuda.kemdikbud.go.id/article.php?article=842863&val>

=11654&title=KAJIAN
EKSPERIMENTAL CAMPURAN
R-32R-290 PENGGANTI
REFRIGERAN R-32 PADA AC
SPLIT DOMESTIK

- [9] S. Raharjo, R. B. Irawan, and M. E. Pujianto, "Optimization of compressor work, power and heat on efficiency refrigerant r290 on split ac," *SINTEK J. J. Ilm. Tek. Mesin*, vol. 16, no. 2, p. 77, 2022, doi: 10.24853/sintek.16.2.77-81.
- [10] G. Li, T. Jin, R. Xu, and Z. Lv, "Comparative Investigation on the Thermophysical Property and System Performance of R1234yf," *Energies*, vol. 16, no. 13, 2023, doi: 10.3390/en16135033.
- [11] W. F. Stoecker, "Refrigeration and refrigerating machinery Air conditioning.," Jakarta: Erlangga, 1996.